

## Conductivity of Liquids and Gases - HT20X

The Armfield Conductivity of Liquids and Gases unit has been specifically designed to enable students to measure and compare the thermal conductivities of various liquids and gases.



HT20X Mimic and control screen

### Hardware Description

The Armfield Conductivity of Liquids and Gases unit has been specifically designed to enable students to measure and compare the thermal conductivities of various liquids and gases. It's designed to facilitate quick and effective cleaning and to minimise thermal losses.

The unit comprises a cylindrical, electrically heated, nickel-plated aluminium core surrounded by a nickel-plated aluminium sleeve. The core and the sleeve are arranged so that a uniform narrow annular gap is created between the two parts, which is filled by the liquid or gas to be analysed.

The temperature on each side of the fluid is measured by thermocouples in the surface of the core and the sleeve.

The HT10X service unit is provided with an electronic proportioning valve and flow meter to control and measure the water flow. The unit incorporates an insulated jacket to minimise heat exchange from and to the atmosphere.

The fluid to be tested is injected into the annular gap between the heated core and the cooled jacket using a hypodermic syringe.

Measurement of the temperature difference between the heated and cooled surfaces together with the power supplied to the heater (measurement of DC voltage and current) using HT10X allows the conductivity of the fluid to be calculated. The surface area and thickness of the fluid sample remain constant during all tests.

## Experimental Capabilities

- ▶ Understanding the use of the Fourier rate equation in determining the rate of heat flow by conduction through liquids or gases
- ▶ Measuring the constant of proportionality (the thermal conductivity  $k$ ) of different liquids such as water and glycerol
- ▶ Calibrating the unit for heat losses using a gas, such as air with known thermal conductivity, then measuring the temperature difference across different gases, such as carbon dioxide and helium to determine their thermal conductivity  $k$

**Note:** *Flammable, explosive, corrosive or toxic liquids and gases must not be used in the equipment.*



## Unique features

- ▶ Thickness of the fluid sample is restricted to 0.5mm to minimise convection in the fluid sample
- ▶ Concentricity of the heated and cooled surfaces is accurately maintained using a spiral insulator
- ▶ Trapped bubbles of the previous liquid or gas sample are prevented by the spiral flow path when injecting a different liquid or gas
- ▶ ArmSoft software is supplied, with separate exercises for determining the thermal conductivity of liquids and gases

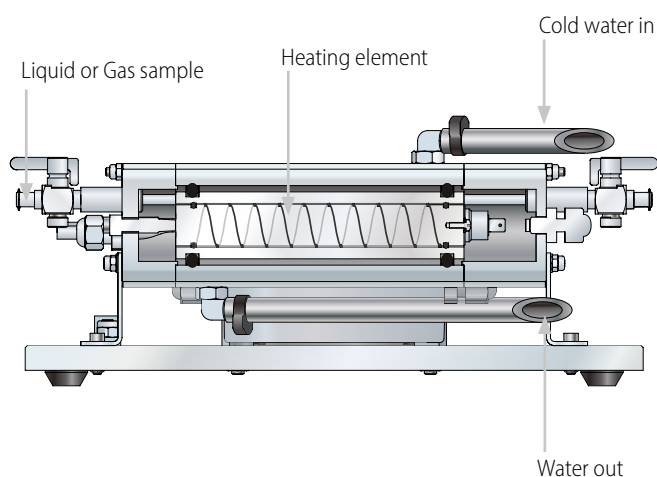

Diagram – HT20X

## Requirements

## Scale

HT  
10X



All electrical requirements are obtained from the service unit

## Essential accessories

HT10X Heat Transfer Service Unit

## Ordering specification

- ▶ A small-scale accessory to allow students to measure the thermal conductivity  $k$  of various liquids and gases
- ▶ Comprises a water-cooled, aluminium outer sleeve surrounding a heated aluminium core creating an annular gap 0.5mm wide that is filled with the fluid under test
- ▶ Nominal heat transfer area  $1.225 \times 10^{-2} \text{ m}^2$
- ▶ Gas or liquid sample volume 6.126ml
- ▶ Heater power is variable up to 200W at 24V using the Heat Transfer Service Unit
- ▶ Overheating is prevented by an integral thermostat
- ▶ Heater can be voltage or PID controlled allowing for the temperature set-point to be achieved rapidly and maintained within 0.1°C.
- ▶ Two k-type thermocouples measure the temperature gradient across the liquid or gas under test
- ▶ Nickel-plated surfaces to minimise radiation losses, narrow annular gap to minimise convection losses and thermally insulated to minimise heat exchange with the atmosphere
- ▶ Includes a pressure regulator to provide a steady flow of cooling water
- ▶ Computer-controlled unit includes an electronic proportioning valve and flow meter to vary and measure the flow of cooling water
- ▶ A comprehensive instruction manual describing how to carry out the laboratory teaching exercises to measure thermal conductivity as well as installation and commissioning is included

## Technical details

Thickness of fluid sample	0.5mm (Fixed by the annular gap)
Nominal heat transfer area	$1.225 \times 10^{-2} \text{ m}^2$
Gas / liquid sample volume	6.126ml
Maximum heater power	200W at 24V
Maximum operating temperature	90°C (limited by integral thermostat)

## Overall dimensions

Length	0.30m
Width	0.25m
Height	0.16m

## Packed and crated shipping specifications

Volume	0.04m <sup>3</sup>
Gross weight	8kg

## Ordering codes

HT20X

Issue: 1

URL: <http://www.armfield.co.uk/ht10x>

Applications

Me ChE CE IP

We reserve the right to amend these specifications without prior notice. E&OE © 2022 Armfield Ltd. All Rights Reserved

[armfield.co.uk](http://armfield.co.uk)