

FT SERIES

The Armfield FT84-12 can be used with an Armfield FT74XTS, FT74XA and FT174X to provide a rapid microwave final heating stage.

The non-contact heating prevents fouling, extends the life of the product and prevents spoiling of delicate ingredients; particularly useful for high protein products.

Microwave UHT add-on – FT84-12

Compatible with Armfield:
FT74XTS, FT174X, FT74X UHT systems



Applications

- ▶ Baby foods
- ▶ Beer
- ▶ Condiments
- ▶ Cream
- ▶ Culture media
- ▶ Custards
- ▶ Desserts
- ▶ Fruit purees
- ▶ Gelatine products
- ▶ Health products
- ▶ Milk
- ▶ Nutritional products
- ▶ Pasta and pâté
- ▶ Pharmaceuticals
- ▶ Puddings
- ▶ Sauces and soups
- ▶ Yoghurts

Description

The Armfield Microwave UHT/HTST unit has been developed for the rapid heating of various types of viscous, nonviscous and even nonhomogeneous products. Product temperatures up to 160°C can be reached.

The product is heated in a short product tube enabling extremely rapid heating rates to be achieved.

This extremely high heating rate reduces negative effects on the physical properties of the product, e.g. denaturation of proteins, vitamins and Maillard reaction.

Another advantage of the microwave unit is that heating occurs throughout the volume of the product.

No heated surface is needed, which prevents burning of the product.

The Microwave UHT/HTST is a user friendly laboratory system for pasteurisation, sterilisation, gelatinisation and other heating processes.

The FT84-12 is an add-on unit, which must be used in conjunction with an Armfield UHT Tubular system (e.g. FT74XA, FT74XTS, FT174X). These FT units are still available for independent use, but the FT84-12 cannot be operated without the UHT system.

By purchasing an FT84-12, existing FT74 owners can upgrade their equipment to a full performance microwave unit at minimum cost (FT74 Plate Heat Exchanger units will need the Tubular Heat Exchanger option as well).

The FT84-12 is placed in-line with the UHT system, using food quality couplings and flexible hoses, enabling the UHT heating section to be used for product preheat.

The FT84-12 includes an initial pre-cooler close to the microwave applicator, with the main cooling provided by the UHT system.

The combination of the UHT (tubular) and the FT84-12 provides complete flexibility and all the advantages of both tubular and microwave heating systems.

Technical specifications

Microwave heating section

Internal diameter: (product side)	10mm
Length microwave section	43mm
Material	Glass
Heating medium	Microwaves 2450 MHz
Microwave power	2000 Watt
Working pressure	10 bar
Throughputs	10-20 l/h for UHT temperatures

Overall dimensions

Length	0.96m
Width	0.66m
Height	1.60m

Packed and crated shipping specifications

Volume	1.63m ³
Gross weight	256Kg

Requirements

Scale



- ▶ Electrical supply: Three phase (see ordering codes)

Features / benefits

- ▶ Minimal negative effects on the physical properties of the product (denaturation of proteins, vitamins, Maillard reaction)
- ▶ No surface 'fouling'
- ▶ Fully flexible time-temperature combinations
- ▶ One system; many products and applications
- ▶ Saves time, ingredients and energy
- ▶ Easy to operate
- ▶ Add-on facility to FT174X, FT74XTS and existing FT74X units
- ▶ Product temperatures up to 160°C
- ▶ Rapid heating of product to 140°C in less than one second
- ▶ Dielectric heating with microwave energy
- ▶ Various holding tubes
- ▶ Versatile
- ▶ Compact, mobile, easy to install
- ▶ Reflected power monitor for fine tuning of the microwave system
- ▶ Temperature output for data logging

Flow Diagram FT84-12

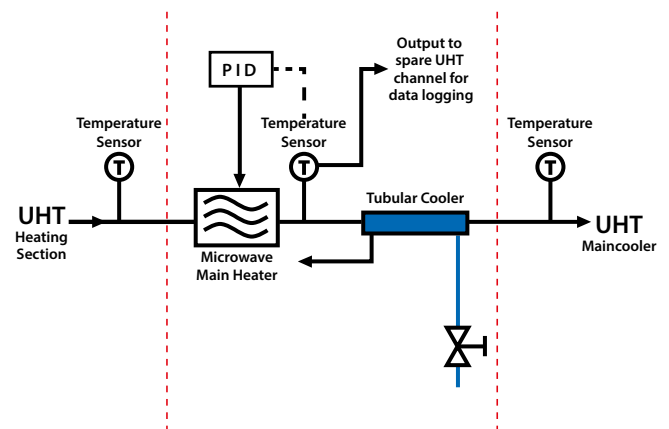

Flow diagram FT84-12

Ordering codes

- ▶ FT84-12-D 208V/3ph/60Hz
- ▶ FT84-12-E 380-415V/3ph/50Hz

Knowledge base

- > 28 years expertise in research & development technology
- > 50 years providing engaging engineering teaching equipment

Benefit from our experience, just call or email to discuss your laboratory needs, latest project or application.

An ISO 9001:2015 Company



armfield.co.uk

Aftercare

Installation
Commissioning
Training
Service and maintenance
Support: armfieldassist.com