

**Batch Solvent Extraction and Desolventising Unit – FT29**

The Armfield FT29 is a floor standing, self contained 25 litre batch process unit demonstrating a variety of solid/liquid extractions.

The unit is particularly suitable for “leaching” edible oils from oil-bearing seeds and desolventising both the extracted solids and the miscella.

**Features / benefits**

- ▶ Self-contained system
- ▶ Floor standing
- ▶ Single extraction/desolventiser vessel
- ▶ Solvent/water recovery tank
- ▶ All flameproof construction
- ▶ ATEX approved
- ▶ Operation of small-scale version of industrial processes
- ▶ A wide variety of solid/liquid extractions may be processed
- ▶ Small quantities (25kg) can be processed
- ▶ Low waste disposal rates

## Description

All vessels, pipes, valves and fittings in contact with process materials are constructed in stainless steel as is the support framework.

The cylindrical extractor/desolventiser with a hinged lid for charging the extraction material, has a base inclined slightly toward a port for discharging the extracted and desolventised meal. Material is supported above the base by a perforated plate covered with a fine-woven mesh so solvent may drain through to the miscella tank while retaining the solids. The vessel base is equipped with an indirect steam chest for process heating.

Direct steam is injected at a variable rate through a distribution pipe positioned above the mesh. A similar distribution pipe positioned near the top of the vessel enables solvent to be sprayed uniformly onto the bed of material. The miscella tank, positioned directly below the extractor to collect the draining liquid, is also a cylindrical vessel incorporating a steam chest as its base.

This vessel also incorporates a direct steam-distribution pipe through which steam can be metered at a variable rate.

Vapour from the vessels, produced in the desolventising process, is directed by ducting to the solvent condenser, which is an inclined shell and tube unit through which water is circulated. Condensate (usually a mixture of solvent and water) drains into the solvent water separator tank, which enables thorough separation of the solvent and water by a gravity process.

*(Note: Only hexane or solvents having a similar specific gravity can be effectively separated in this tank).*

Solvent reclaimed from this vessel can then be recirculated by the solvent pump at a regulated rate through a variable area flow meter. Excess water overflows to a waste water tank from where it can be disposed of on completion of the process. Operation at reduced system pressures are achieved by a PTFE diaphragm type vacuum pump. The outlet of this pump is piped through a flame arrester to a suitable ventilation point.

Each vessel is equipped with suitable level/sight glasses so that the processes can be observed and monitored. Pressure and temperature gauges are supplied where necessary as are adequate sampling and drain valves.

Hexane is the most widely used solvent in the extraction process and due to the flammable nature of this product, electrical equipment has been kept to a minimum.

Where electrical equipment must be used, it is specified to the appropriate standards for safety.

The main processing vessels have been designed in accordance with the appropriate code of practice for welded pressure vessels.

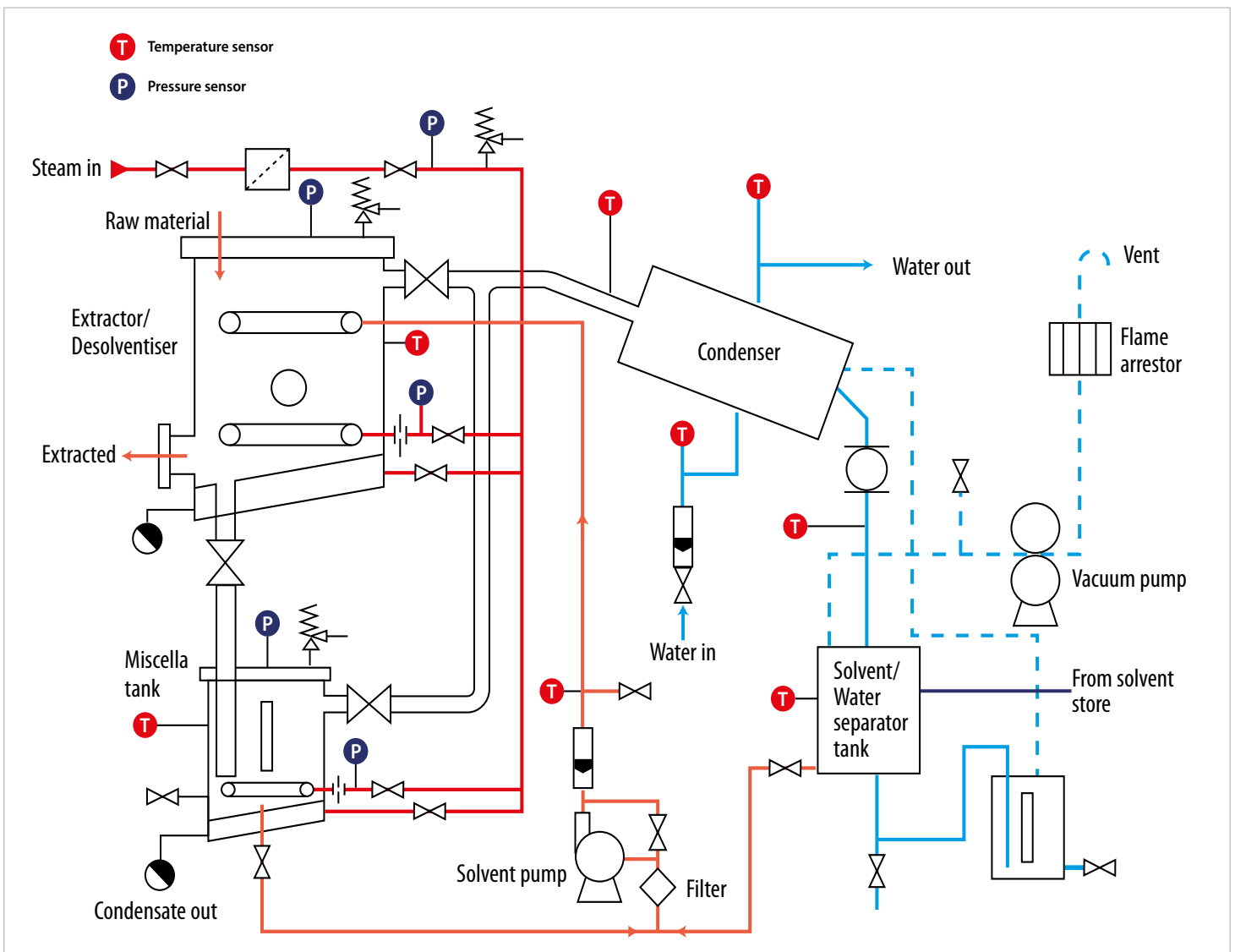

Schematic diagram of the FT29

## Modes of operation

### Extraction by recirculating miscella:

This involves priming the miscella tank with clean solvent then pumping the solvent to the extractor where it percolates through the material bed and drains as miscella back into the tank for recirculation.

### Extraction by washing with clean solvent:

As miscella is formed, steam admitted to the miscella tank base causes solvent to evaporate. The vapour is condensed in the solvent condenser and returns to the separator tank from which it is pumped back to the extractor.

### Desolventising extracted material:

When the extraction is complete, the static hold-up of solvent remaining in the material must be removed and this is achieved using a combination of direct and indirect steam and vacuum.

The solvent vaporises and is condensed along with the condensate. The mixture of solvent and water is separated in the solvent water separator tank. When the extracted material is free of solvent it is discharged through the door at the base of the extractor.

### Desolventising miscella:

Miscella is a mixture of the solvent and oil from the extraction material, which accumulates in the miscella tank during the process. The solvent and oil are separated in a similar method as for material desolventising using a combination of direct and indirect steam and vacuum.

A higher level of vacuum is required than for material desolventising in order to produce solvent-free oil.

*Within each mode of operation, many operating parameters such as process temperature, solvent temperature, solvent flow rate, direct steam flow rate and system pressure can be adjusted to enable a high degree of experimentation.*



Condenser flow handle

## Capabilities

- ▶ Effect of degree of pretreatment of solid material on extraction efficiency
- ▶ Effect of solvent type
- ▶ Effect of solvent percolation rate
- ▶ Effect of process temperature and pressure
- ▶ Effect of extraction time and drain time
- ▶ Method and degree of solvent recovery

## Examples of extractions possible using the FT29

Extraction material	Extract	Solvent
Oil seeds/presscakes	Edible oil	Hexane
Tree bark	Tannin	Water
Solanium (agras)	Steroid	Dil.sulphuric acid
Pyrethrum flower	Insecticide	Hexane
Tea leaves	Tea	Water
Wheat germ	Oil	Hexane
Rice bran	Oil	Hexane
Poppy Stalks	Morphine	Water
Flowers/fruits	Essential oils	Hexane
Liquorice roots	Liquorice juice	Water



Inspecting the interior of the extractor vessel

## Technical specifications

Extractor vessel	
Volume	100 litres
Batch capacity	25kg based on density of 560 kg/m <sup>3</sup>
Direct steam	0-7 kg/h
Indirect steam	0-3.5 bar
Miscella tank	
Volume	30 litres
Minimum extract	2 litres
Direct steam	0-4 kg/h
Indirect steam	0-3.5 bar
Solvent condenser	
Condensing capacity	2.5kW
Condensing area	2.5m <sup>2</sup>
Cooling medium	Water
Cooling water flow range	0-22 l/m
Solvent water separator tank	
Volume of separator section	16 litres
Volume of solvent store	16 litres
Waste water tank	
Total volume	15 litres
Vacuum pump	
Type	Double PTFE diaphragm
Drive	Flameproof AC motor
Operating pressure	100mbar (max)
Solvent pump	
Type	Gear
Drive	Flameproof AC motor
Solvent flow range	0-18 l/m with bypass flow control

## Requirements Scale



- ▶ Electricity supply: Three phase (see ordering codes)
- ▶ Water supply: 25 l/m @ 3 (min)  
For cooling -5 (max) bar pressure
- ▶ Steam supply: 20 kg/hr @ 5 bar min pressure

## Overall dimensions

Length	1.90m
Width	0.90m
Height	1.75m
Packed and crated shipping specifications	
Volume	5.8m <sup>3</sup>
Gross weight	880kg



Desolventiser / extractor vessel with viewing port

## Ordering codes

- ▶ FT29-C: 415V/3ph/50Hz, (0.6kW)
- ▶ FT29-D: 208V/3ph/60Hz, (0.6kW)
- ▶ FT29-E: 380V/3ph/50Hz, (0.6kW)
- ▶ FT29-F: 220V/3ph/60Hz, (0.6kW)

## Knowledge base

- > 28 years' expertise in research & development technology
- > 50 years' providing engaging engineering teaching equipment

Benefit from our experience, just call or email to discuss your laboratory needs, latest project or application.

An ISO 9001:2015 Company



[armfield.co.uk](http://armfield.co.uk)

## Aftercare

Installation  
Commissioning  
Training  
Service and maintenance  
Support: [armfieldassist.com](http://armfieldassist.com)